

Fenac Inductive Contactless Encoders

FNC ASI 37 Series



Technical data - Electrical Ratings

Supply Voltage	5V or 6 - 36 VDC \pm 5%
Interface	SSI or BISS
Protection	Overvoltage protection Short-circuit protection
Resolution (steps/turn)	up to 17 bit
Output frequency	up to 2 MHz for SSI up to 10 MHz for BISS
Code	Binary
Output circuit	SSI data linedriver RS485
Interference immunity	DIN EN 61000-6-2
Emitted interference	DIN EN 61000-6-4
Approval	CE

Features

- Non contact inductive technology
- High accuracy
- For high reliability in extreme environments
- Robust mechanical design
- Thin design

Technical data - Mechanical Ratings

Dimensions	Outer Diameter : 37 mm Inner Diameter : 6, 6.5, 8 mm
Mounting Type	Clamping or Screw
Mounting Gap	0.5 mm \pm 0,1
Materials	Anodized Aluminium
Protection DIN EN 60529	IP 67
Operating temperature	-40 ... +85°C
Weight	Rotor : 30 g Stator : 100 g

Fenac Inductive Contactless Encoders



FNC ASI 37 Series

Cable Wiring

Function	Connector	Color
+VB	pin 10	Brown
GND	pin 9	White
CLK+	pin 8	Blue
CLK-	pin 6	Blue-Black
DATA+	pin 5	Orange
DATA-	pin 7	Orange-Black
ZERO*	pin 1	Gray
FACTORY ZERO**	pin 2	Gray-Black

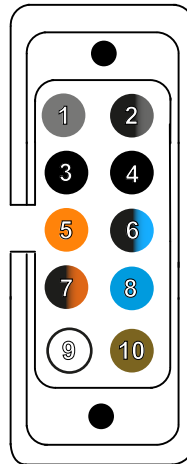

During operation;

* : To set the Zero position, apply GND to Zero pin for more than 100msec.

** : To set the Factory Zero position to factory default, apply GND to Factory Zero pin for less then 1 second.

*** : If these pins are not used, please connect to 5V with a pull-up resistor.

Communication Interface

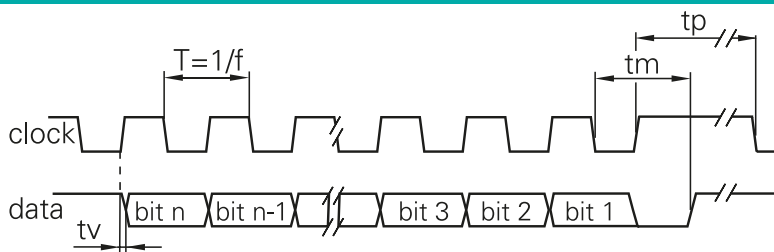

Clock frequency, f	100 ... 2000 kHz for SSI 100 ... 10.000 kHz for BISS
Code	Binary
Status and parity bit	On request
Monoflop time t_m	20 μ s
Delay time t_v	<150 ns

Communication Hardware

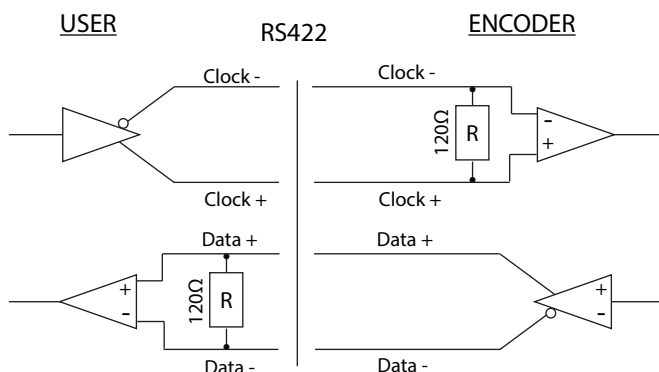

Fenac Inductive Contactless Encoders



FNC ASI 37 Series

Mechanical Dimensions

Screw Mounting Stator - Setscrew Mounting Rotor Version

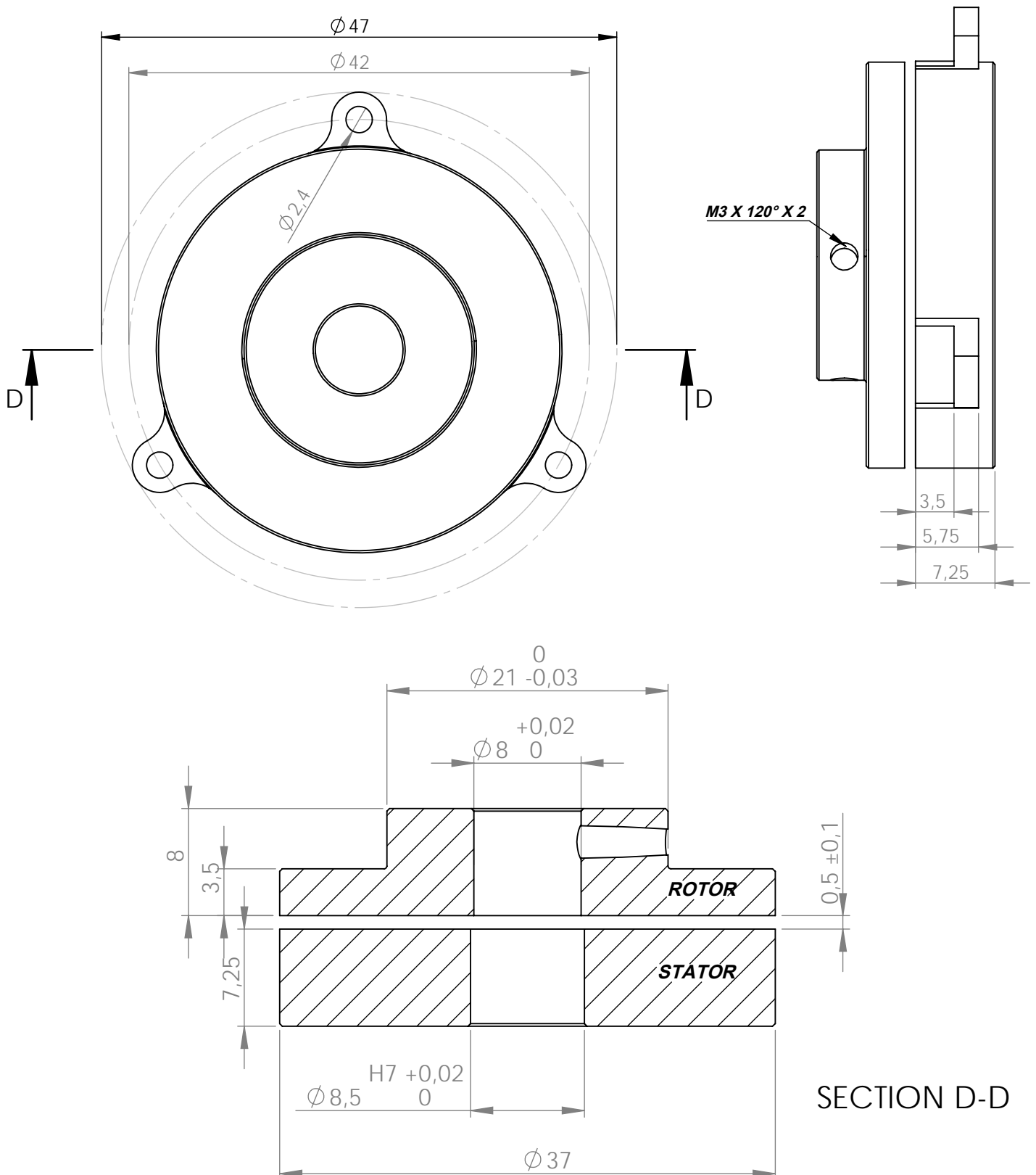

FNC ASI 37 Series

Mechanical Dimensions

Screw Mounting Stator - Plain Rotor Version

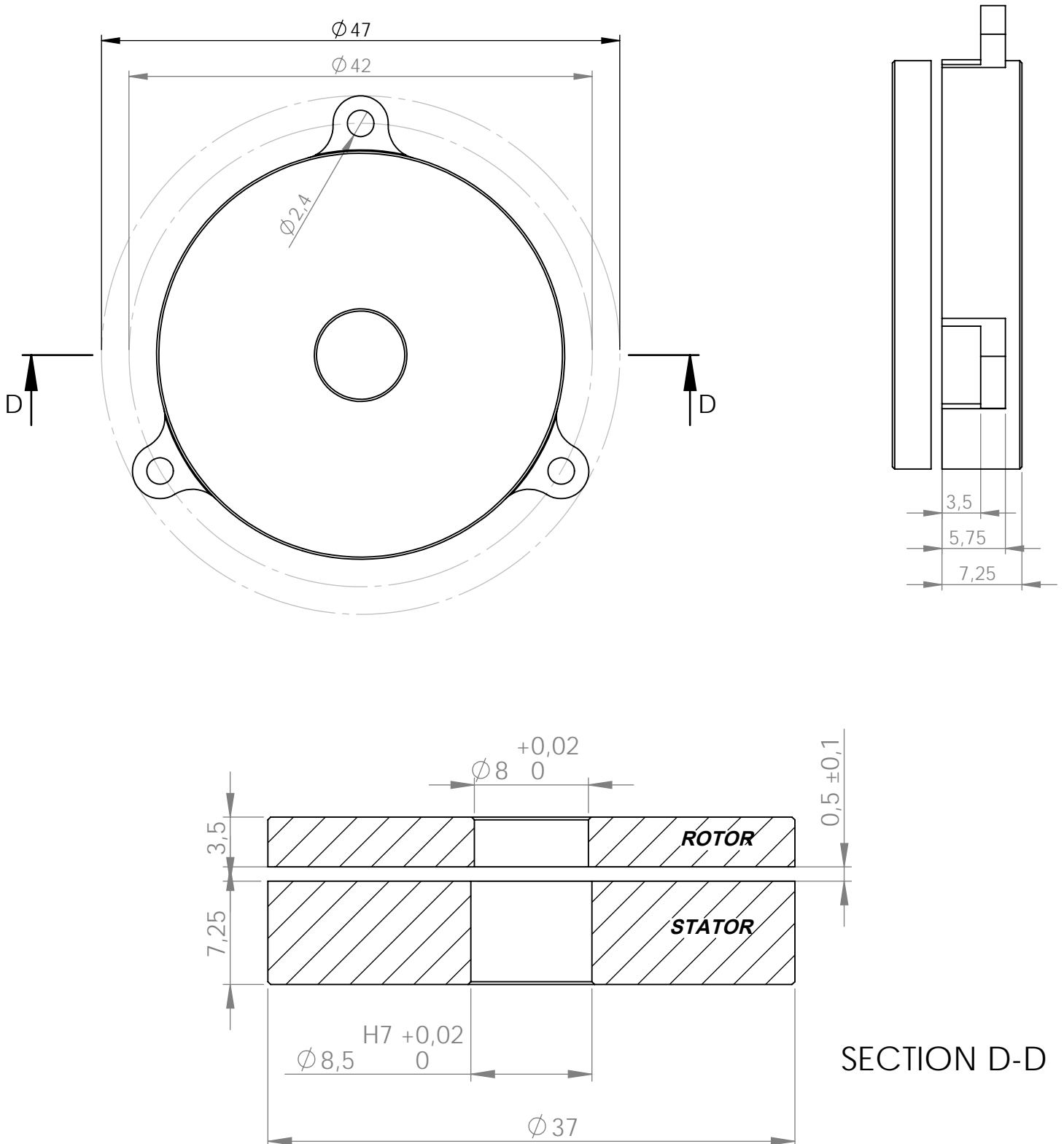

Fenac Inductive Contactless Encoders



FNC ASI 37 Series

Mechanical Dimensions

Servo Clamp Stator - Setscrew Mounting Rotor Version

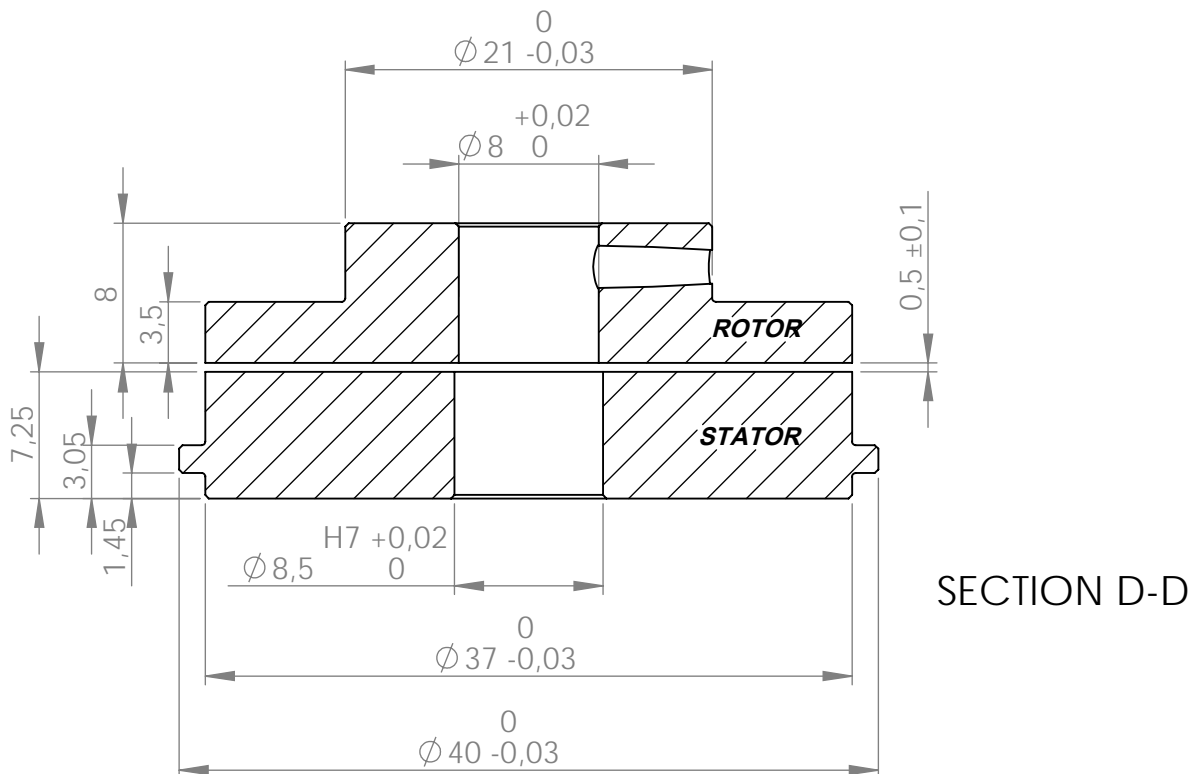
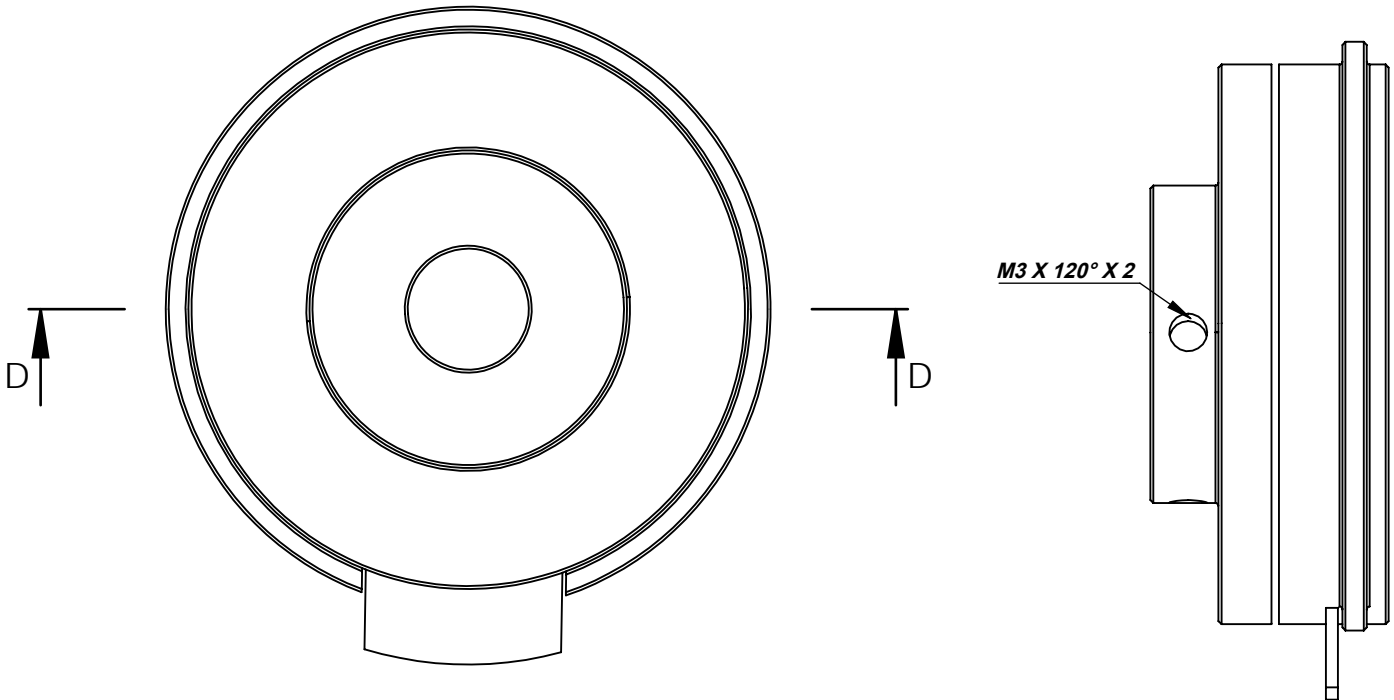

FNC ASI 37 Series

Mechanical Dimensions

Screw Clamp Stator - Plain Rotor Version

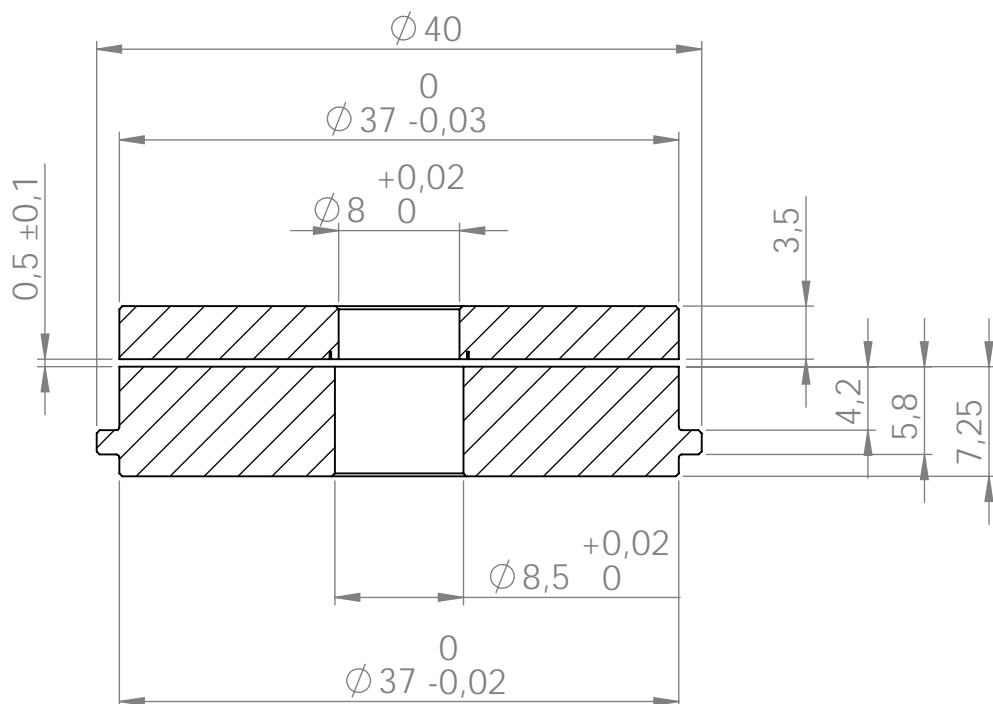
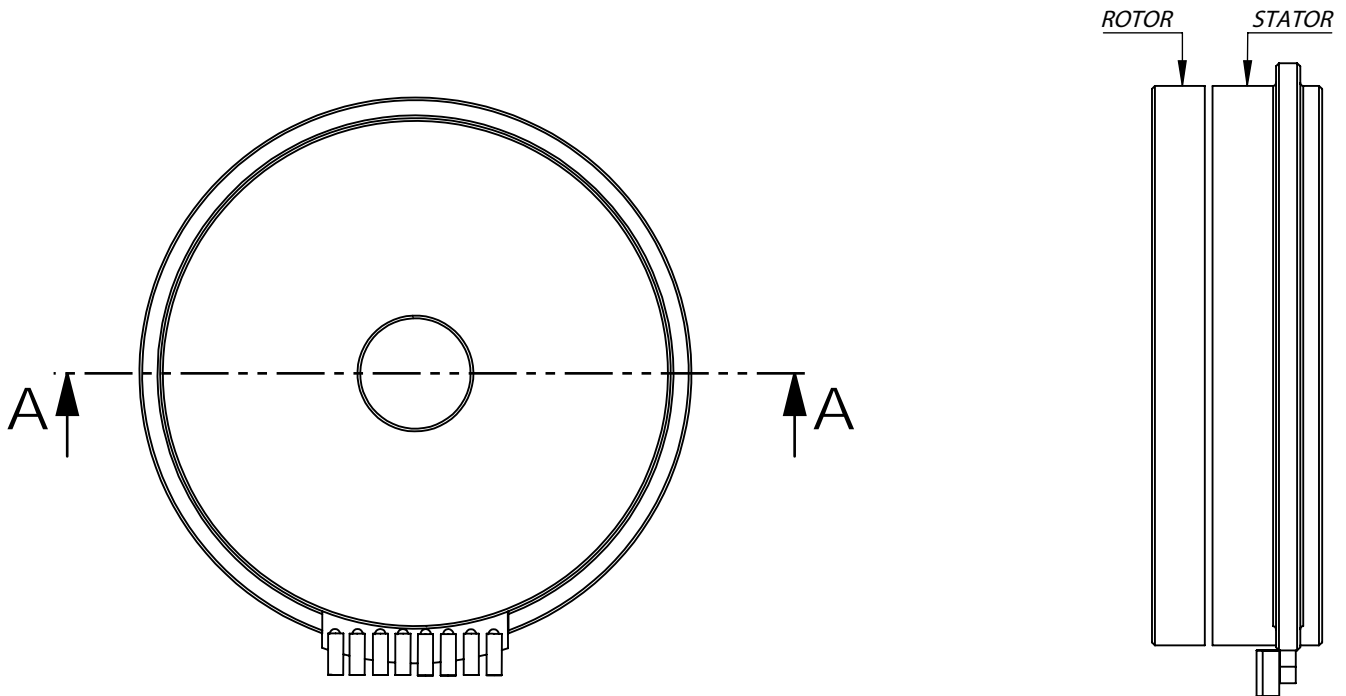

FNC ASI 37 Series

SSI (Synchronized Serial Interface) Product Options

SSI1 (n = 24)

D23	D22	D21	D20	...	D1	D0
E	ZPD	PD				

E : Error Flag. Set to 1 when data is valid, otherwise 0

ZPD : Zero Point Default. Set to 1 when the Zero Point is at Factory Default, otherwise 0

PD : Binary position data. If resolution of device is less than 22 bits, then the MSBs of this field are set to 0. The LSB of this field is in D0. When PV is 0, PD[21:0] value is not defined.

SSI2 (n = 24)

D23...D2	D1	D0
PD[21:0]	P	A

PD : Binary position data. If resolution of device is less than 22 bits, then the MSBs of this field are set to 0. The LSB of this field is in D2. When Alarm bit is 1, PD[21:0] value is not defined.

P : Parity Bit 0 indicates an even number of 1's in data (D23-D2), 1 indicates an odd number of 1's in data.

A : Alarm Bit - 0 indicates normal operation, 1 indicates error condition.

SSI3 (n = 16)

D15	D14	D13	D12	...	D1	D0
PD [15:0]						

PD : Binary position data. When ERROR FLAG is 1, PD[15:0] value is not defined.

SSI7 (n = 30)

D29...D24	D23...D2	D1	D0
Z	PD[21:0]	P	A

Z : Data always 0.

PD : Binary position data. If resolution of device is less than 22 bits, then the MSBs of this field are set to 0. The LSB of this field is in D2. When Alarm bit is 1, PD[21:0] value is not defined.

P : Parity Bit 0 indicates an even number of 1's in data (D23-D2), 1 indicates an odd number of 1's in data.

A : Alarm Bit - 0 indicates normal operation, 1 indicates error condition.

BISS (Bidirectional Synchronized Serial Interface) Product Options

BISS (n = 24)

D23...D8	D7	D6	D5...D0
PD[15:0]	nE	nW	CRC

PD : Binary position data.

nE : Error Flag. Low active.

nW : Warning Flag. Low active.

CRC : Cyclic Redundancy Check, 0x43 polynomial

Fenac Inductive Contactless Encoders



FNC ASI 37 Series

