

FNC HW 100 Series



Features

- Axis selection switch**
- Rate override switch**
- Reset switch**
- 100 ppr standard encoder**
- Voltage output**
- 5-30V wide supply range**
- Line driver output**

Pulse diagram

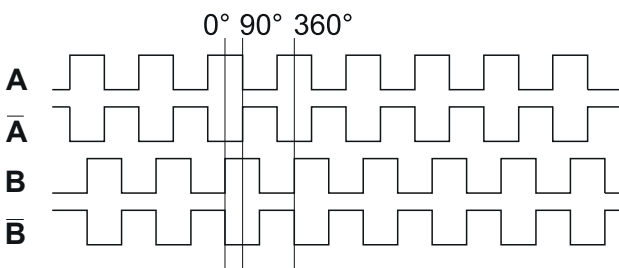

Technical data - electrical ratings

Operating voltage	+5V .. 30V (Hand wheel)
Output type	RS422 (Hand wheel)
Output signals	90° shifted A and B, inverted
Frequency response	0 - 5 kHz
Current consumption	max 60mA
Utilization category	250 VAC /3A (Emergency stop)
Switching capacity (VA)	max. 0,2VA
Switching voltage	max. DC 50V push buttons max. 15V selector switch max. AC32V push buttons

Technical data - mechanical ratings

Encoder material	Shaft: Stainless steel Housing : Aluminum Cover : ABS
Hand wheel material	Housing : ABS
Normal rotational speed	max 200 r / min
Operating temperature	-10...+80°C
Weight approx.	450 g

Mechanical Dimensions

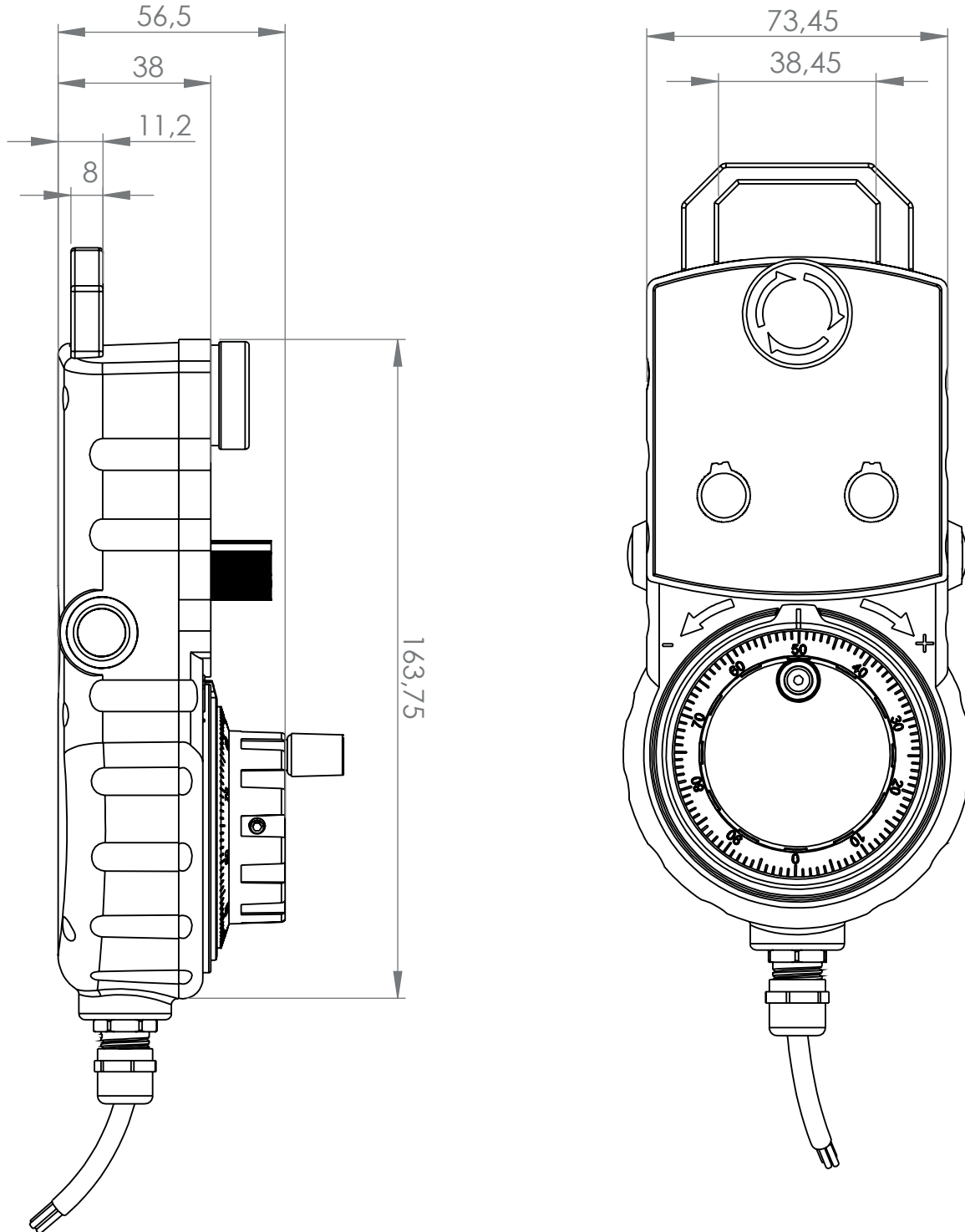

FNC HW 100 Series

Mechanical Dimensions

EMERGENCY STOP

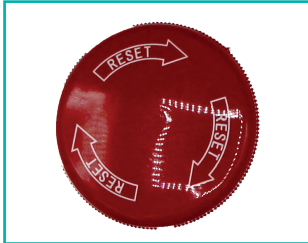

HANGER

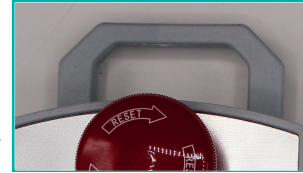

AXIS SELECTION SWITCH

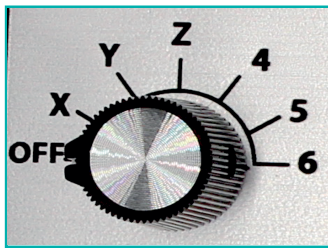

RATE OVERRIDE SWITCH

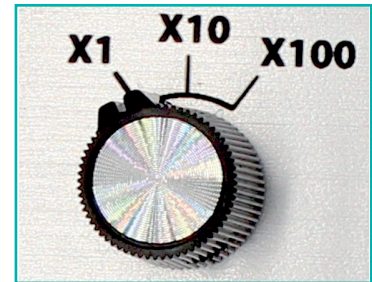







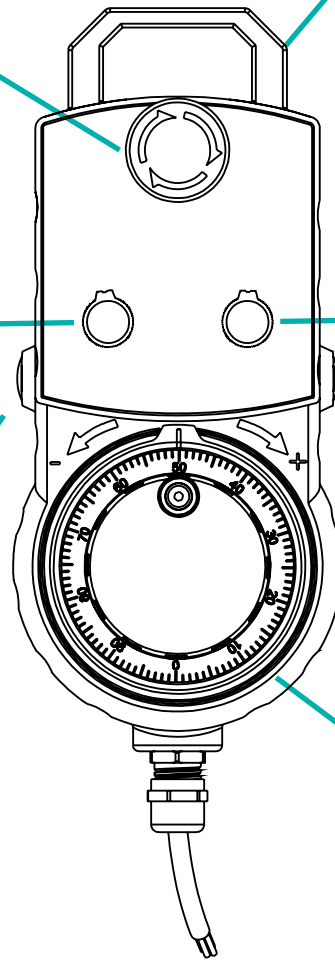











SAFETY SWITCH



100 PPR ENCODER



Cable Connection

Function	Color	Renk
+VCC		Brown Kahverengi
GND		White Beyaz
A		Green Yeşil
A'		Red Kırmızı
B		Yellow Sarı
B'		Pink Pembe
X1		Gray Gri
X10		Purple Mor
X100		Orange Turuncu
COM		Orange-Black Turuncu-Siyah
X		Gray-Black Gri-Siyah
Y		Purple-Black Mor-Siyah
Z		Green-Black Yeşil-Siyah
4		Yellow-Black Sarı-Siyah
5		Red-Black Kırmızı-Siyah
6		Pink-Black Pembe-Siyah
EM1		Blue Mavi
EM2		Blue-Black Mavi-Siyah

